



Southwire™

# NM CABLE CATALOG

**BUILT FOR DURABILITY.  
BUILT FOR RELIABILITY.  
BUILT FOR WORK.™**

[SOUTHWIRE.COM](http://SOUTHWIRE.COM)

# NM CABLE FITTINGS

---

Southwire offers a broad range of UL Listed metallic and non-metallic Cable connectors suitable for Romex® Brand and NM cable. Available in Snap-in, compression and traditional strap type enclosures, our fittings accommodate a wide range of cable sizes.

Metallic and Non-metallic Romex® Brand Connectors

SE Round Connectors

Snap-in Romex® Brand Connectors

NM Straps

Combination Couplings

UF Connectors

Zinc Flexible Cord Connectors

Steel Flexible Cord Connectors



# NM CLAMP TYPE CONNECTORS

## 3/8" NM CABLE

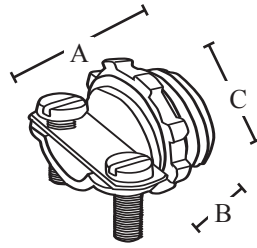
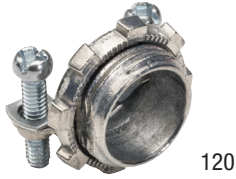

### FEATURES

- Fits NM Cable: #14/2, #12/2, #12/3, AWG or 2 # 14/2 AWG or flex cord .300 to .560 inches diameter 3/8" (1/2" KO)

### APPLICATIONS

- For connecting non-metallic cable to box or enclosure

### STANDARD MATERIAL

- Zinc die cast

### CERTIFICATIONS

- cULus

PART #	SIZE	FITS CABLE	INNER QTY.	MASTER QTY.	WEIGHT/ CASE (LBS.)	A	B	C
120	3/8" 1/2"KO	NM CABLE FROM 2#14-2 WITH GROUND AND 2#12-2 WITH GROUND	100	1000	50	.814"	.44"	.92"

# NM ROMEX® BRAND SNAP CONNECTOR

## 3/8" NM CABLE



120SNP

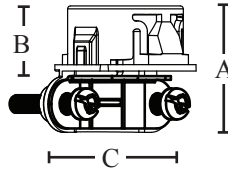

### FEATURES

- Fits NM Cable: #14/2, #12/2, #12/3, AWG or 2 # 14/2 AWG or flex cord .300 to .560 inches diameter 3/8" (1/2" KO)
- Snap-In connection, no lock nut required

### APPLICATION

- For connecting non-metallic cable to box or enclosure

### STANDARD MATERIAL

- Zinc die cast

### CERTIFICATIONS

- cULus

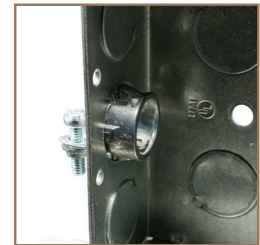

PART #	SIZE	FITS CABLE	INNER QTY.	MASTER QTY.	WEIGHT/ CASE (LBS.)	A	B	C
120SNP	3/8" 1/2"KO	NM CABLE FROM 2#14-2 WITH GROUND AND 2#12-2 WITH GROUND	50	500	25	.866"	.30"	1.18"

# ROMEX™ BRAND NMSC CONNECTOR

NON-WATERTITE - ZINC DIE CAST



RXCN38



L-104

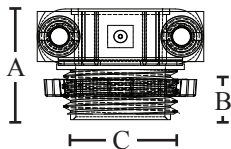

## FEATURES

- Two screw

## APPLICATIONS

- Connects Romex® Brand NMSC to a box or enclosure

## STANDARD MATERIAL

- Zinc die cast

## CERTIFICATIONS

- UL Listed, CSA Listed

PART #	SIZE	INNER QTY.	MASTER QTY.	A	B	C
RXCN38	3/8" 1/2"KO	100	1000	.78	.323	.629
L-104	3/4"	50	500	.917	.338	.838

## SNAP-IN - PVC



ME-3202



## FEATURES

- Max. service temperature 105°C
- Snap-in, No locknut required

## APPLICATIONS

- Connects Romex® Brand NMSC to a box or enclosure

## STANDARD MATERIAL

- PVC

## CERTIFICATIONS

- UL Listed, CSA Listed

PART #	CABLE RANGE	SIZE	INNER QTY.	MASTER QTY.
ME-3202	(1) 6/3 TO 8/3, (2) 12/3 TO 8/2	3/4"	25	250

NIM CABLE FITTINGS

# NM CLAMP TYPE CONNECTORS

## FOR OVAL NM CABLE



953

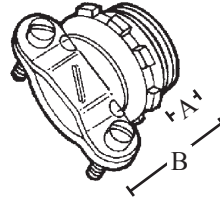

### FEATURES

- Two tri-combo screws and zinc die cast locknut

### APPLICATIONS

- In a dry location, use to connect non-metallic sheathed cable to a steel outlet box or other metal enclosure

### STANDARD MATERIAL

- Zinc die cast

### CERTIFICATIONS

- cULus

PART #	SIZE	FITS CABLE	INNER QTY.	MASTER QTY.	WEIGHT/ CASE (LBS.)	A	B
952TZ	3/4"	OVAL NM 8-2 TO 6-3	25	250	19	.42"	1.03"
953	1"	OVAL NM 8-3 TO 4-3	25	250	34	.57"	1.20"
954	1-1/4"	OVAL NM 4-3 TO 1-3	10	100	23	.64"	1.32"
955	1-1/2"	OVAL NM 1-3 TO 1/0-3	10	100	31	.60"	1.32"
956	2"	OVAL NM 1/0-3 TO 4/0-3	5	50	25	.71"	1.55"

All above take 2 cables

## FOR NM AND SE ROUND CABLE



143R

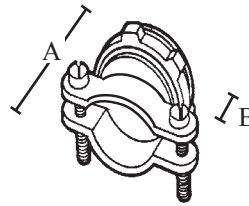

### FEATURES

- Non-watertight
- Two screws

### APPLICATIONS

- Indoor use only
- In a dry location, use to connect non-metallic sheathed cable to a steel outlet box or other metal enclosure

### STANDARD MATERIAL

- Zinc die cast

### CERTIFICATIONS

- cULus

PART #	SIZE	FITS CABLE	INNER QTY.	MASTER QTY.	WEIGHT/ CASE (LBS.)	A	B
143R	1"	SE CABLE 6-3, 4-3, 4-2, 2-2 NM CABLE 12-3, 12-4, 10-3, 10-4, 8-3, 8-2, 6-2, 4-2	25	250	37	1.19"	.645"
144R	1-1/4"	SE CABLE 10-2, 8-2, 6-2, 4-2 NM CABLE 8-3, 6-3, 4-3, 2-3	10	100	24	1.33"	.66"
145R	1-1/2"	SE CABLES 3-3, 3-2, 3-1	10	100	34	1.47"	.74"
146R	2"	SE CABLES 3-4/0	5	50	23	1.62"	.75"

# NM SNAP-IN CONNECTORS



459



458

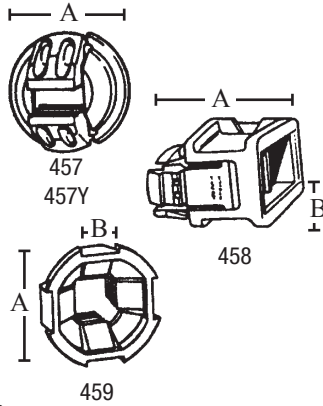

## FEATURES

- 1/2" or 3/4" knockouts

## APPLICATIONS

- Multiple knockout sizes accommodate many applications
- Connects NM cable in a dry location

## STANDARD MATERIAL

- Plastic

## CERTIFICATIONS

- cULus

PART #	KO SIZE	WIRE SIZE	INNER QTY.	MASTER QTY.	WEIGHT/ CASE (LBS.)	A	B
457	1/2"	ONE : 14/2 OR 14/3, ONE: 12/2, OR 12/3 ONE: 10/2 OR 10/3	100	1000	5	1"	---
457Y*	1/2"	ONE : 14/2 OR 14/3, ONE: 12/2, OR 12/3 ONE: 10/2 OR 10/3	100	1000	5	1"	---
458	1/2"	2-WIRE TWO : 14/2 OR 12/2 ONE : 14/2 OR 12/2 ONE : 14/2 OR 10/2 ONE : 12/2 OR 10/2	50	500	9	1.25"	.25"
459	3/4"	ONE : 14/3 OR 12/3 ONE : 10/2, 8/3 OR 6/3	50	500	5	1.0938"	.375"

\* Yellow

# CABLE CONNECTORS

## NM SHEATHED



RCR50



RCR75

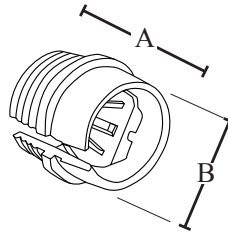

### FEATURES

- RCR50 easily installs in all 1/2" metal knockouts
- RCR75 easily installs in all 3/4" metal knockouts
- Locknut not required
- Retrofit design allows you to install from the inside or outside of enclosure

### APPLICATIONS

- Remodel work or new construction
- For use with non-metallic sheathed cable to box or enclosure

### STANDARD MATERIAL

- Plastic 105°C rated

PART #	KO SIZE	CABLE RANGE		INNER QTY.	MASTER QTY.	WEIGHT/ CASE (LBS.)	A	B
		ONE CABLE	TWO CABLE					
RCR50	1/2"	14/2, 12/2, 10/2, 14/3, 12/3, 10/3	14/2, 12/2, 14/3	100	1000	4	1"	.50"
RCR75	3/4"	8/3, 6/3	---	50	500	3	1.10"	.75"

# NM BOX CONNECTORS

## 2 PIECE CLAMP BUTTERFLY TYPE

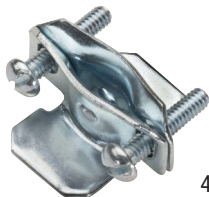

441

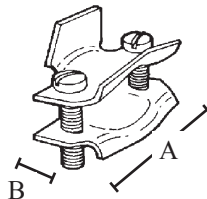

### FEATURES

- Versatile 2 piece clamp butterfly style design

### APPLICATIONS

- For connecting non-metallic cable to box or enclosure

### STANDARD MATERIAL

- Steel

PART #	SIZE	FITS CABLE	INNER QTY.	MASTER QTY.	WEIGHT/ CASE (LBS.)	A	B
441	3/8" TO 1/2"	2 OR 3#14, 12, 10, 8	100	1000	50	1.31"	.64"
442	3/4" TO 1"	2 OR 3#8, 6, 4	50	500	35	1.75"	.765"
444	1-1/4"	#2/0	25	250	25	2.12"	.765"
445	1-1/2"	#3/0, #4/0	25	250	40	2.50"	.78"

# COMBINATION CABLE CONNECTORS

## 2 SCREW CLAMP TYPE



140TZ

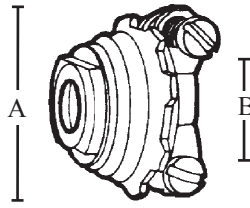

### FEATURES

- 2 screw clamp type

### APPLICATIONS

- Indoor use only
- In a dry location, use to connect flexible metallic conduit, AC, MC, MCI-A, HCF and NM cable to steel outlet box or other enclosure
- 3/8" size fits 1/2" knockout

### STANDARD MATERIAL

- Zinc

PART #	SIZE	KO	INNER QTY.	MASTER QTY.	WEIGHT/ CASE (LBS.)	A	B (MIN. - MAX.)
140TZ	3/8"	1/2"	100	1000	60	1.192"	.18" - .63"

# ALL PURPOSE CONNECTORS

## TWIN SCREW

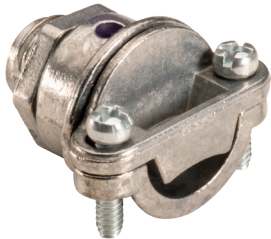

NC25

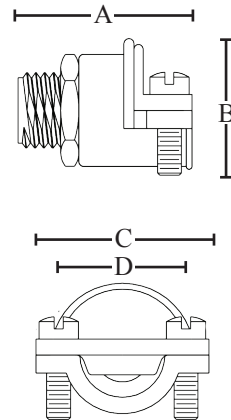

### FEATURES

- Securely holds cable in low profile fixtures with 1/4" knockouts
- Concrete tight when taped

### APPLICATIONS

- Fore use with non-metallic, AC, MC, sheathed, flexible metal conduit cable both steel and aluminum jacketed
- Mainly used with low silhouette florescent fixtures, additional connectors are needed when multiple fixtures are wired in

### STANDARD MATERIAL

- Zinc die cast

### CERTIFICATIONS

- cULus

PART #	SIZE	KO	INNER QTY.	MASTER QTY.	WEIGHT/ CASE (LBS.)	CABLE RANGE	END STOP DIAMETER	A	B
NC25	3/8"	1/4"	50	500	31	.225-.612	0.38	1.04"	0.92"

# NM STRAP

## 1 HOLE



510RX

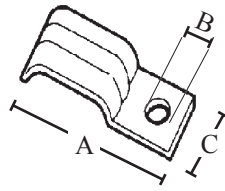

### FEATURES

- Inverted rib provides extra strength

### APPLICATIONS

- Securely affix cables, tubing, pipe and EMT

### STANDARD MATERIAL

- Steel

PART #	SIZE	INNER QTY.	MASTER QTY.	WEIGHT/ CASE (LBS.)	A	B	C
510RX	14/2, 12/2	100	1000	14	1.08"	.28"	.50"

# COMBINATION COUPLINGS

SET SCREW TO CLAMP TYPE - EMT TO BX  
OR NM CABLE ZINC DIE CAST



180

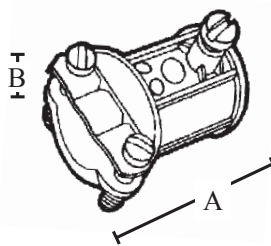

### FEATURES

- Set screw to clamp type
- Combination coupling used to join NM cable to EMT

### APPLICATIONS

- Indoor use only
- Use to join EMT to nonmetallic sheathed cable, #14/2, #12/3 or 2 #14/2

### STANDARD MATERIAL

- Zinc die cast
- Zinc plated steel strap

### CERTIFICATIONS

- cULus



PART #	SIZE	INNER QTY.	MASTER QTY.	WEIGHT/ CASE (LBS.)	A	B (MIN. - MAX.)
180	1/2" - 3/8"	50	500	40	1.35"	.17" - .63"

# DUPLEX CONNECTORS

2 SCREW - CLAMP TYPE - FOR BX, FLEX,  
NM & MC CABLE ZINC

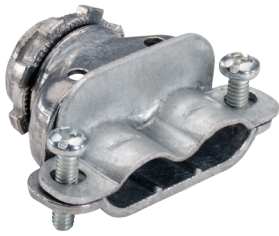

360

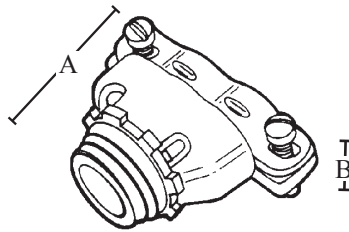

## FEATURES

- Duplex 2 screw clamp type
- UL listed locknut
- Male hub NPT
- Tri-combo screw head

## APPLICATIONS

- Indoor dry location use only
- Strap-type fitting used to connect flexible metal conduit or armored cable to box or enclosure

## STANDARD MATERIAL

- Zinc die cast
- Zinc plated steel strap

## CERTIFICATIONS

- cULus

PART #	SIZE	KO SIZE	INNER QTY.	MASTER QTY.	WEIGHT/ CASE (LBS.)	A	B (MIN. - MAX.)
360	3/8"	1/2"	25	250	32	1.68"	.24" - .63"

CABLE TYPE	CABLE SIZE	CABLE DIAMETER
ARMORED CABLE, STEEL	14/2 - 10/3	.48" - .58"
ARMORED CABLE, ALUMINUM	14/2 - 10/3	.46" - .50"
MCI-ALUMINUM	14/2 - 10/3	.488" - .81"
MCI-STEEL	14/2 - 10/3	.47" - .60"
MCI-A, ALUMINUM	14/2 - 10/3	.37" - .495"
HCF, MCI A ALUMINUM	12/2 - 10/2	.418" - .495"

2 SCREW - CLAMP TYPE - FOR BX, FLEX,  
NM & MC CABLE MALLEABLE IRON



360M

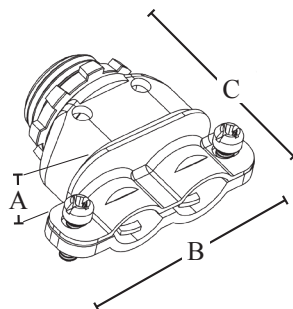

## FEATURES

- Duplex 2 screw clamp type
- UL listed locknut
- Male hub NPT
- Tri-combo screw head

## APPLICATIONS

- Indoor dry location use only
- Strap-type fitting used to connect flexible metal conduit or armored cable to box or enclosure

## STANDARD MATERIAL

- Malleable iron

## CERTIFICATIONS

- cULus

PART #	SIZE	KO SIZE	INNER QTY.	MASTER QTY.	WEIGHT/ CASE (LBS.)	A	B	C
360M	3/8"	1/2"	10	100	16	.83"	2.17"	1.59"

NM & MC CABLE FITTINGS

# DUPLEX CONNECTORS

1 SCREW CLAMP TYPE - FOR BX, FLEX, NM & MC CABLE



350

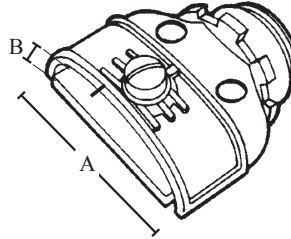

PART #	SIZE	KO SIZE	INNER QTY.	MASTER QTY.	WEIGHT/ CASE (LBS.)	A	B (MIN. - MAX.)
350	3/8"	1/2"	25	250	32	1.57"	.13" - .65"

## FEATURES

- Fits aluminum smooth extruded MC range .210-.500
- Indoor use only
- Suitable for: #14-2 through #12-3 wire with ground NM sheathed cable, #14-2 wire steel armored cable, #14-2 wire with ground aluminum armored cable, 3/8" FMC, aluminum smooth sheath metal clad cable 0.410-0.500" diameter aluminum interlocked metal clad cable 0.460-0.538" diameter, steel interlocked metal clad cable 0.438-0.560" diameter
- 3/8" size fits 1/2" knockout

## APPLICATIONS

- In a dry location, use to connect two pieces of flexible metallic conduit, AC, MC, or NM sheathed cable, to a steel outlet box or other metal enclosure when using only one knockout opening

## STANDARD MATERIAL

- Zinc

## CERTIFICATIONS

- cULus

# TAKE ALL CONNECTORS

MC, AC, NM, ROUND SE



TA50

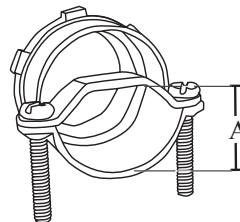

PART #	SIZE	INNER QTY.	MASTER QTY.	WEIGHT/ CASE (LBS.)	CABLE DIAMETER A (MIN. - MAX.)
TA50	1/2"	25	250	18	.68" - .85"
TA75	3/4"	20	200	20	.94" - 1.08"
TA100	1"	10	100	14	1.15" - 1.25"
TA125	1-1/4"	10	100	21	1.34" - 1.45"
TA150	1-1/2"	5	50	14	1.70" - 1.845"
TA200	2"	5	50	19	2.07" - 2.18"

## FEATURES

- Indoor dry location use only
- UL listed for MC, AC, NM, and SE round cables
- Reversible steel strap for multiple applications
- Tri-combination screw heads

## APPLICATIONS

- Use to connect MC, AC, NM and round SE into box or enclosure

## STANDARD MATERIAL

- Zinc body
- Zinc locknut
- Zinc plated steel screws
- Reversible steel strap

## CERTIFICATIONS

- cULus

# WATERTIGHT CONNECTORS

## COMPRESSION TYPE



873

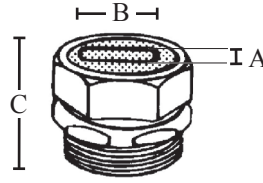

### FEATURES

- Compression type
- Rubber grommet

### APPLICATIONS

- Use to secure SE/SEU cable to metal enclosures
- For SE/SEU flat style cable; two insulating conductors

### STANDARD MATERIAL

- Zinc die cast

### CERTIFICATIONS

- UL, CSA

PART #	SIZE	WIRE SIZE	INNER QTY.	MASTER QTY.	WEIGHT/ CASE (LBS.)	GROMMET OPENING		C
						A	B	
873	1"	3#8	10	100	34	.41" x .65"	1.875"	
873A	1"	3#6	10	100	34	.46" x .715"	1.875"	
873B	1"	3#4	10	100	34	.53" x .85"	1.875"	
874	1-1/4"	3#3	10	100	52	.55" x .91"	1.937"	
874A	1-1/4"	3#2	10	100	52	.58" x .96"	1.937"	
874B	1-1/4"	3#1	10	100	52	.66" x 1.12"	1.937"	
875	1-1/2"	3#1/0	5	50	33	.705" x 1.195"	2.375"	
875A	1-1/2"	3#2/0	5	50	32	.74" x 1.235"	2.375"	
876	2"	3#1/0	5	50	44	.705" x 1.195"	2.25"	
876A	2"	3#2/0	5	50	44	.74" x 1.235"	2.25"	
876B	2"	3#3/0	5	50	44	.83" x 1.415"	2.25"	
876C	2"	3#4/0	5	50	44	.85" x 1.54"	2.25"	
876D	2"	3#4/0	5	50	44	.995" x 1.58"	2.25"	

## FOR UF CABLE



871

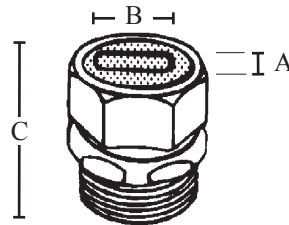

### FEATURES

- Compression type
- Rubber grommet

### APPLICATIONS

- Use to secure SE/SEU cable to metal enclosures
- Use to connect UF cable to a waterproof box with a threaded hub
- For SE/SEU flat style cable; two insulating conductors

### STANDARD MATERIAL

- Steel or zinc die cast

### CERTIFICATIONS

- UL

PART #	SIZE	WIRE SIZE	INNER QTY.	MASTER QTY.	WEIGHT/ CASE (LBS.)	GROMMET OPENING		C
						A	B	
<b>ZINC</b>								
871	1/2"	2#14	25	250	43	.22" x .44"	1.437"	
872TZ	3/4"	3#14	25	250	65	.22" x .44"	1.75"	

# LIQUIDTIGHT CORD GRIPS

## NPT HUBS - 6/6 NYLON



LTF12

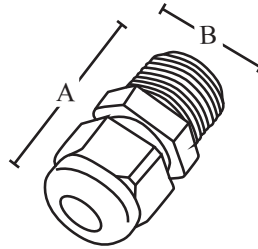

### FEATURES

- Liquidtight at up to 70 P.S.I. water pressure
- Acme threads on body prevent skipping and speed installation
- Multiple sizes for cable diameters
- Suitable for NEMA type 6 enclosures
- IP68 Rating
- Locknuts sold separately

### APPLICATIONS

- Indoor or outdoor use
- Prevents cable pullout and controls arc of bend

### STANDARD MATERIAL

- 6/6 nylon

### CERTIFICATIONS

- UL

PART #	SIZE	CABLE DIAMETER		SUGGESTED CLEARANCE HOLE DIAMETER	INNER QTY.	MASTER QTY.	WEIGHT/ CASE (LBS.)	A	B
		MIN.	MAX.						
LTF12	1/2"	.17"	.450"	.875"	25	100	3	1.53"	.93"
LTF34	3/4"	.45"	.709"	1.04"	10	100	5	1.97"	1.30"
LTF1	1"	.59"	1"	1.326"	10	100	6	2.42"	1.65"

# FLEXIBLE CORD CONNECTORS

## STRAIN RELIEF - ZINC DIE CAST



882

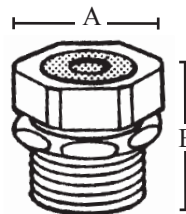

### FEATURES

- Provides excellent strain relief for indoor and outdoor use
- Prevents cable pullout
- Provides tight seal against elemental damage

### APPLICATIONS

- Indoor and outdoor use

### STANDARD MATERIAL

- Zinc die cast

### CERTIFICATIONS

- UL, CSA

PART #	SIZE	GROMMET COLOR	CABLE RANGE	INNER QTY.	MASTER QTY.	WEIGHT/ CASE (LBS.)	A	B	RANGE	
									MIN.	MAX.
881	1/2"	RED	.190" - .260"	25	250	43	.96"	1.30"	.19"	.26"
881A	1/2"	BLUE	.260" - .375"	25	250	43	.96"	1.30"	.26"	.375"
881B	1/2"	GREEN	.375" - .500"	25	250	43	.96"	1.30"	.375"	.50"
882	3/4"	GREEN	.375" - .500"	25	250	65	1.20"	1.32"	.44"	.50"
882A	3/4"	BROWN	.500" - .625"	25	250	65	1.20"	1.32"	.50"	.625"
882B	3/4"	ORANGE	.625" - .750"	25	250	65	1.20"	1.32"	.625"	.725"
883A	1"	BROWN	.500" - .625"	10	100	34	1.51"	1.58"	.50"	.625"
883B	1"	ORANGE	.625" - .750"	10	100	34	1.51"	1.58"	.625"	.75"
883C	1"	BLACK	.750" - .880"	10	100	34	1.51"	1.58"	.75"	.88"
883D	1"	PURPLE	.880" - .985"	10	100	34	1.51"	1.58"	.875"	.985"

# FLEXIBLE CORD CONNECTORS

## STRAIN RELIEF - STEEL



50A250

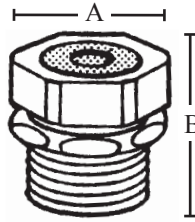

### FEATURES

- Grommets enhance sealing for additional protection
- Provides excellent strain relief
- For indoor and outdoor use
- Prevents cable pullout

### APPLICATIONS

- Provides tight seal against elemental damage

### STANDARD MATERIAL

- Steel

### STANDARD FINISH

- Zinc plated

### CERTIFICATIONS

- UL, CSA

PART #	SIZE	GROMMET COLOR	CABLE RANGE	INNER QTY.	MASTER QTY.	WEIGHT/ CASE (LBS.)	A	B
50A250	1/2"	RED	.15" - .25"	---	25	3	.975"	1.937"
50A350	1/2"	WHITE	.25" - .35"	---	25	3	.975"	1.937"
50A450	1/2"	BLUE	.35" - .45"	---	25	3	.975"	1.937"
50A560	1/2"	GREEN	.45" - .56"	---	25	3	.975"	1.937"
50A650	1/2"	BROWN	.55" - .65"	---	25	3	.975"	1.937"
75A250	3/4"	RED	.15" - .25"	---	25	3	1.22"	1.937"
75A350	3/4"	WHITE	.25" - .35"	---	25	3	1.22"	1.937"
75A450	3/4"	BLUE	.35" - .45"	---	25	3	1.22"	1.937"
75A560	3/4"	GREEN	.45" - .56"	---	25	3	1.22"	1.937"
75A650	3/4"	BROWN	.55" - .65"	---	25	3	1.22"	1.937"
75B750	3/4"	YELLOW	.65" - .75"	---	25	3	1.22"	1.562"
75B850	3/4"	PURPLE	.75" - .85"	---	25	3	1.22"	1.562"
100B560	1"	GREEN	.45" - .56"	10	100	28	1.50"	1.75"
100B650	1"	BROWN	.55" - .65"	10	100	28	1.50"	1.75"
100B750	1"	YELLOW	.65" - .75"	10	100	28	1.50"	1.75"
100B850	1"	PURPLE	.75" - .85"	10	100	28	1.50"	1.75"
100C950	1"	GRAY	.85" - .95"	10	100	28	1.50"	1.875"
100C1050	1"	BLACK	.95" - 1.05"	10	100	28	1.50"	1.875"

Larger sizes available  
See specifications on next page

# FLEXIBLE CORD CONNECTORS

## STRAIN RELIEF - STEEL

Cable Chart for Flexible Cord Connectors

PART #	SIZE	CABLE RANGE MIN. MAX.	FOR TYPES SO, ST, & STO	FOR TYPES S.J, STO, SJT SJTO, SVO, AND BUS DROP FOR VNTC TYPE TRAY CABLE	FOR VNTC TYPE TRAY CABLE
50A250	1/2"	.15 - .25	---	18-2,3 SVO	---
50A350	1/2"	.25 - .35	---	18-2,3 SJT 18-2,3,4 SJO 16-2,3 SJO	18-3,4 & 5 16-3 & 4 14-3
50A450	1/2"	.35 - .45	18-2,3,4 16-2,3,4	16-4 SJO 14-2,3,4 SJO 12-2 SJO 14-3 BUS DROP	18-6 TO 18-11 16-5 TO 16-8 14-4 TO 14-7 12-3 & 4 ALSO COMPOSITE CABLES 3 # 16 & 4 # 14
50A560	1/2"	.45 - .56	18-5,6,7 16-5,6 14-2,3	12-3 SJO 12-3 & 10-3 BUS DROP	18-10 TO 18-16 16-9 TO 16-12 14-8 TO 14-9 12-5 & 12-7 10-3 TO 10-4 ALSO COMPOSITE CABLES 3 # 12 & 4 # 14 3 # 10 & 4 # 14
50A650	1/2"	.55 - .65	18-8,10 16-7,8 14-4 12-2,3 10-2	---	18-17 TO 18-23 16-13 TO 16-19 14-10 TO 14-14 12-8 & 9 10-5 TO 10-7 8-2 TO 8-4 ALSO COMPOSITE CABLES 3 # 8 & 4 # 14 3 # 10 & 4 # 12
75A250	3/4"	.15 - .25	---	18-2,3 SVO	---
75A350	3/4"	.25 - .35	---	18-2,3 SJT 18-2,3,4 SJO 16-2,3 SJO	18-3,4 & 5 16-3,4 14-3
75A450	3/4"	.35 - .45	18-2,3,4 16-2,3,4	16-4 SJO 14-2,3,4 SJO 12-2 SJO 14-3 BUS DROP	18-6 TO 18-11 16-5 TO 16-8 14-4 TO 14-7 12-3 & 4 ALSO COMPOSITE CABLES 3 # 16 & 4 # 14
75A560	3/4"	.45 - .56	18-5,6,7 16-5,6 14-2,3	12-3 SJO 12-3 & 10-3 BUS DROP	18-10 TO 18-16 16-9 TO 16-12 14-8 TO 14-9 12-5 TO 12-7 10-3 TO 10-4 ALSO COMPOSITE CABLES 3 # 12 & 4 # 14 3 # 10 & 4 # 14
75A650	3/4"	.55 - .65	18-8,10 16-7,8 14-4 12-2,3 10-2	---	18-17 TO 18-23 16-13 TO 16-19 14-10 TO 14-14 12-8 & 9 10-5 TO 10-7 8-2 TO 8-4 ALSO COMPOSITE CABLES 3 # 8 & 4 # 14 3 # 10 & 4 # 12
75B750	3/4"	.65 - .75	18-12,14 16-10,12 14-5,6,7 12-4,5 10-3,4 8-2	8-3 BUS DROP	18-24 TO 18-37 16-20 TO 16-27 14-15 TO 14-21 12-5 TO 12-7 10-3 TO 10-4 ALSO COMPOSITE CABLES 3 # 6 & 4 # 14 3 # 8 & 4 # 12
75B850	3/4"	.75 - .85	18-16,18,20 16-14,16,18 14-8 12-6,7,8 10-5 8-3,4 6-2	6-3 BUS DROP	16-28 TO 16-33 14-22 TO 14-26 12-15 TO 12-19 10-10 TO 10-11 6-4 4-2 ALSO COMPOSITE CABLES 3 # 6 & 4 12 3 # 6 & 6 # 14 3 # 6 & 6 # 12
100B560	1"	.45 - .56	18-5,6,7 16-5,6 14-2,3	12-3 SJO 12-3 & 10-3 BUS DROP	18-10 TO 18-16 16-9 TO 16-12 14-8 TO 14-9 12-5 TO 12-7 10-3 TO 10-4 ALSO COMPOSITE CABLES 3 # 12 & 4 # 14 3 # 10 & 4 # 14
100B650	1"	.55 - .65	18-8,10 16-7,8 14-4 12-2,3 10-2	---	18-17 TO 18-23 16-13 TO 16-19 14-10 TO 14-14 12-8,9 10-5 TO 10-7 8-2 TO 8-4 ALSO COMPOSITE CABLES 3 # 8 & 4 # 14 3 # 10 & 4 # 12
100B750	1"	.65 - .75	18-2,14 16-10,12 14-5,6,7 12-4,5 10-3,4 8-2	8-3 BUS DROP	18-24 TO 18-37 16-20 TO 16-27 14-15 TO 14-21 12-10 TO 12-14 10-8 TO 10-9 6-3 ALSO COMPOSITE CABLES 3 # 6 & 4 # 14 3 # 8 & 4 # 12
100B850	1"	.75 - .85	18-16,18,20 16-14,16,18 14-8 12-6,7,8 10-5 8-3,4 6-2	6-3 BUS DROP	16-28 TO 16-33 14-22 TO 14-26 12-15 TO 12-19 10-10 TO 10-11 6-4 TO 4-2 ALSO COMPOSITE CABLES 3 # 6 & 4 # 12 3 # 6 & 6 # 14 3 # 6 & 6 # 12
100C950	1"	.85 - .95	18-22,24,26 16-20,22,24 14-10,12 10-6,7,8 6-3,4	4-3 BUS DROP	16-34 TO 16-37 14-27 TO 14-33 12-20 TO 12-23 10-12 4-3 ALSO COMPOSITE CABLES 3 # 4 & 4 # 14 3 # 4 & 4 # 12
100C1050	1"	.95 - 1.05	18-30 16-26 14-14,16 12-10 4-3	---	14-34 TO 14-37 12-24 TO 12-30 4-4 2-2 2-3 ALSO COMPOSITE CABLES 3 # 2 & 4 # 14 3 # 2 & 4 # 12 3 # 2 & 6 # 14

NM CABLE FITTINGS

# KNOCKOUT BUSHINGS

6/6 NYLON



SB87510



PART #	INSIDE DIAMETER	KO SIZE	INNER QTY.	MASTER QTY.	WEIGHT/ CASE (LBS.)
SB87510	5/8"	1/2"	100	1000	4
SB87511	11/16"	1/2"	100	1000	4
SB109313	13/16"	3/4"	100	1000	6
SB109314	7/8"	3/4"	100	1000	6
SB109315	15/16"	3/4"	100	1000	6
SB137514	7/8"	1"	100	1000	8
SB137516	1"	1"	100	1000	8
SB175022	1-3/8"	1-1/4"	50	500	6
SB200026	1-5/8"	1-1/2"	50	500	7
SB2.531	1-31/32"	2"	10	100	4
SB3.039	2-15/32"	2-1/2"	10	100	4

## FEATURES

- Suitable for use with electrical knockouts

## APPLICATIONS

- For use in mounting panels up to 1/4" thick, convert raw edged holes to smooth, neat, insulated holes
- Insulate and mechanically protect electrical and telecommunications cables, tubing, hose, rope and utility lines
- Locking fingers snap into holes with fingertip pressure; capable of withstanding a push back force of greater than 35 pounds

## STANDARD MATERIAL

- 6/6 nylon

# UNIVERSAL BUSHINGS

BLACK - 6/6 NYLON



UB875

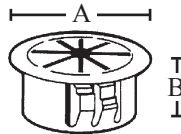

PART #	MOUNTING HOLE DIAMETER	KO	INNER QTY.	MASTER QTY.	WEIGHT/ CASE (LBS.)	A	B	MAX. INSIDE DIAMETER
UB625	.625	---	100	1000	4	.719"	.406"	.437"
UB875	.875	1/2"	100	1000	4	.938"	.453"	.562"
UB1000	1	---	100	1000	5	1.063"	.453"	.75"
UB1093	1.093	3/4"	100	1000	5	1.156"	.453"	.812"

## FEATURES

- .125 maximum thickness
- Flexible shutters accommodate a variety of shapes
- Easy snap in installation

## APPLICATIONS

- Absorbs vibration to better cushion cables and tubing with limited internal clearance

## STANDARD MATERIAL

- 6/6 Nylon



**Southwire™**

# NM CABLE CATALOG

**get social with us:**



[/SOUTHWIRETOOLS](#)



[/SOUTHWIRE-COMPANY](#)



[@SOUTHWIRETOOLS](#)



[@SOUTHWIRE](#)



SCAN TO LEARN MORE

[WWW.SOUTHWIRE.COM](http://WWW.SOUTHWIRE.COM) | 1-855-SWT00LS

All Trademarks or Registered Trademarks (TM/®) are owned or licensed by Southwire Company.  
Any other TM/®- Trademark or Registered Trademark of Southwire Company.